

SECTION 33

PRE-FABRICATED PRODUCTS

WORK BENCHES

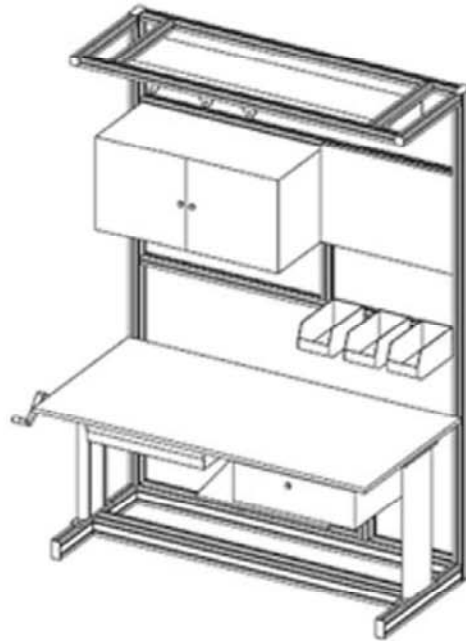

STANDARD BASES



Prefab Prod.

PRE-FABRICATED WORK BENCHES

Work Bench #1

Standard work bench with options for table tops, along with options for mounting drawers, access strips, etc...



Work Bench #2

Similar to #1, but having extensions capable of mounting shelves, lights, parts containers, etc...

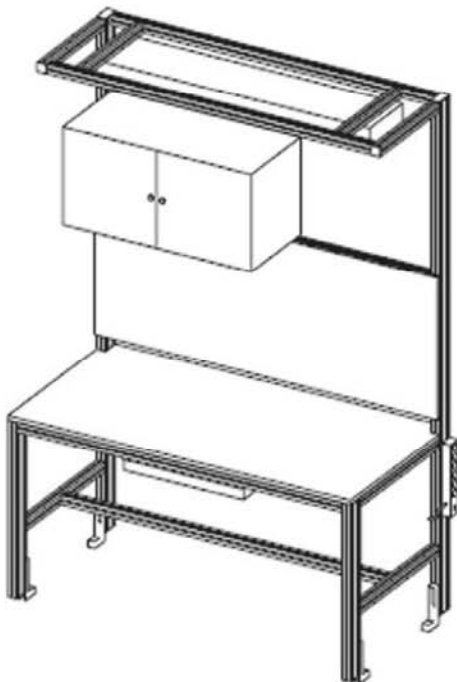

Work Bench #3

Has all the features of #2 plus a hydraulic lift, allowing for ergonomic height adjustment for table tops.

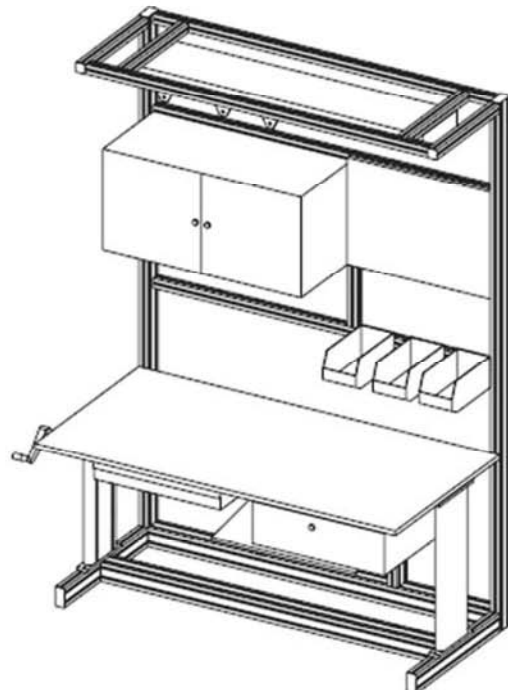

Work Bench #1

Accessory Options

- Drawer
- Pencil Drawer
- Table Top
- Electrical Strip

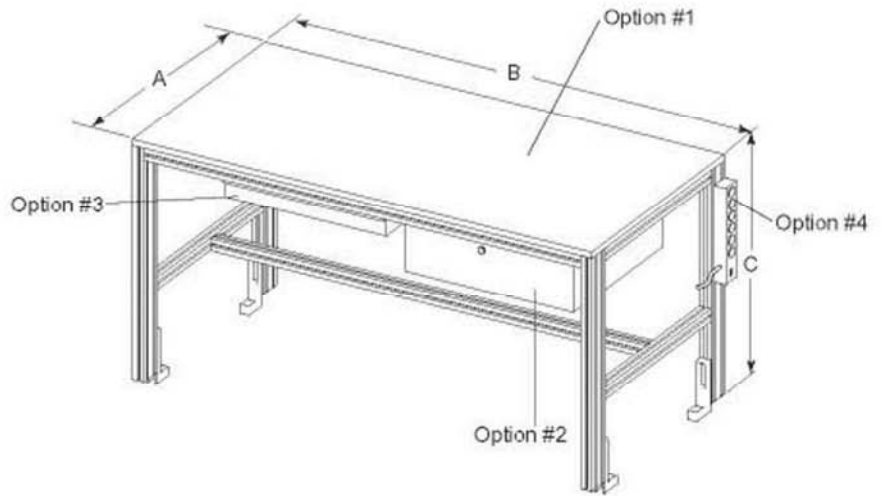

A	_____ (Minimum with drawer is 24")
B	_____ (Minimum with both drawers is 40")
C	_____
D	Option #1 Table Top - Please specify material
D1	Stainless Steel
D2	Formica
D3	Hardwood Laminate
D4	Polypropelene
E	Option #2 Drawer w/ Sliding Tray & Keyed Lock
E1	13AC7462 - 16" w x 20"d x 6.75"h
E2	13AC7463 - 22" w x 20"d x 6.75"h
F	Option #3 Pencil Drawer
	13AC7460 - 21" w x 24"d x 3.00"h
G	Option #4 Electrical Access Strip

Example for Ordering:

WB1 - A - B - C - D1 - E2 - F - G
 (1-4) (1-2)

Work Bench #2

Accessory Options

- Tool Hanger
- Drawers
- Parts Containers
- Table Tops
- Electrical Strip
- Light Fixtures
- Shelves

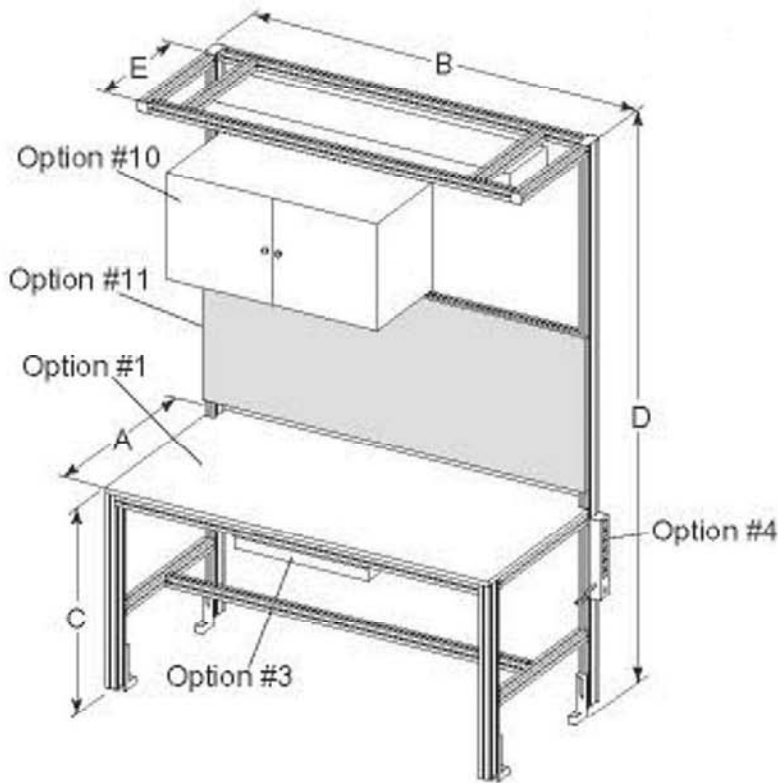
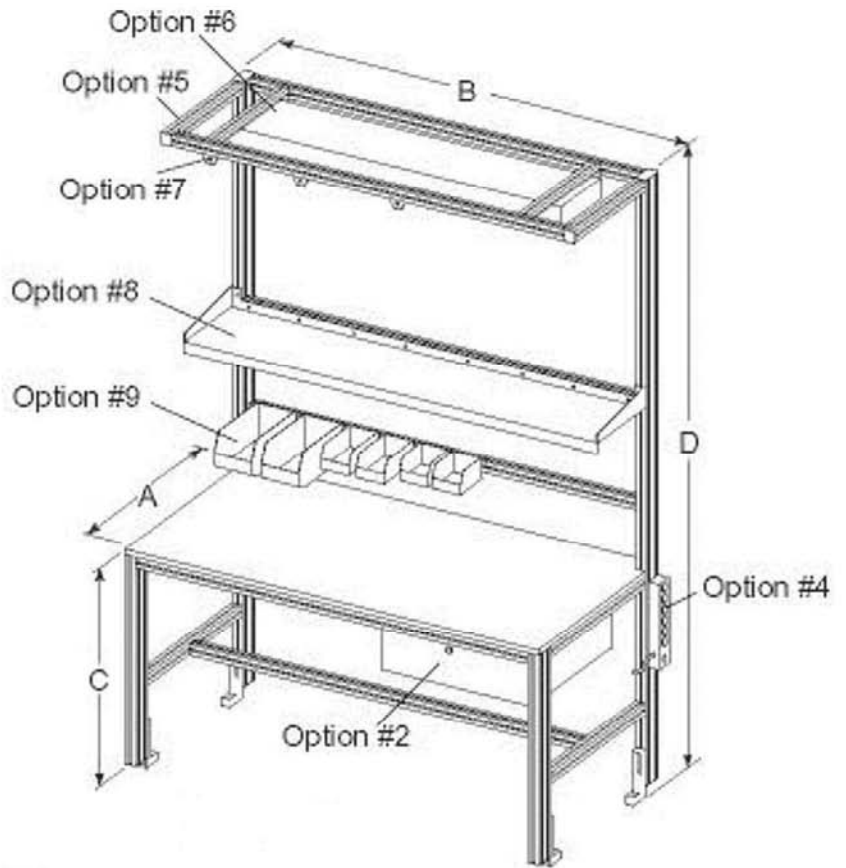

Example for Ordering:

WB2 - A - B - C - D - E - F1 - G1 - H - J - K - L1 - M - N - P1 - R1 - S
 (1-4) (1-2) (1-2) (1-4) (1-2)

A	_____ . _____ (Minimum with drawer is 24")
B	_____ . _____ (Minimum with both drawers is 40")
C	_____ . _____
D	_____ . _____
E	_____ . _____ (If needed)
F	Option #1 Table Top - Please specify material
F1	Stainless Steel
F2	Formica
F3	Hardwood Laminate
F4	Polypropelene
G	Option #2 Drawer w/ Sliding Tray & Keyed Lock
G1	13AC7462 - 16" w x 20"d x 6.75"h
G2	13AC7463 - 22" w x 20"d x 6.75"h
H	Option #3 Pencil Drawer
	13AC7460 - 21" w x 24"d x 3.00"h
J	Option #4 Electrical Access Strip
K	Option #5 Overhead Extension w/ Endcaps
L	Option #6 Light Fixture
L1	13AC7672 - 24" LG
L2	13AC7674 - 48" LG
M	Option #7 Tool Hanger
N	Option #8 Shelf - Specify Width
	Width _____ . _____
	Width _____ . _____
P	Option #9 Parts Container - Specify Color (Red, Blue, or Yellow)
P1	13AC7202 - 3"H x 4.13"D x 5.38"W
P2	13AC7203 - 3"H x 4.13"D x 5.38"W
P3	13AC7204 - 3"H x 4.13"D x 5.38"W
P4	13AC2105 - Parts Container Hanger
R	Option #10 Personal Effects Locker
R1	Keyed Lock
R2	Padlock Hasp
S	Option #11 Tack Board (Specify Size)

Length _____ . _____ x Width _____ . _____

Work Bench #3

Accessory Options

- Tool Hanger
- Drawers
- Parts Containers
- Table Top
- Electrical Strip
- Light Fixtures
- Shelves
- Foot Rest
- Hydraulic Capacity of 500lbs or 750lbs

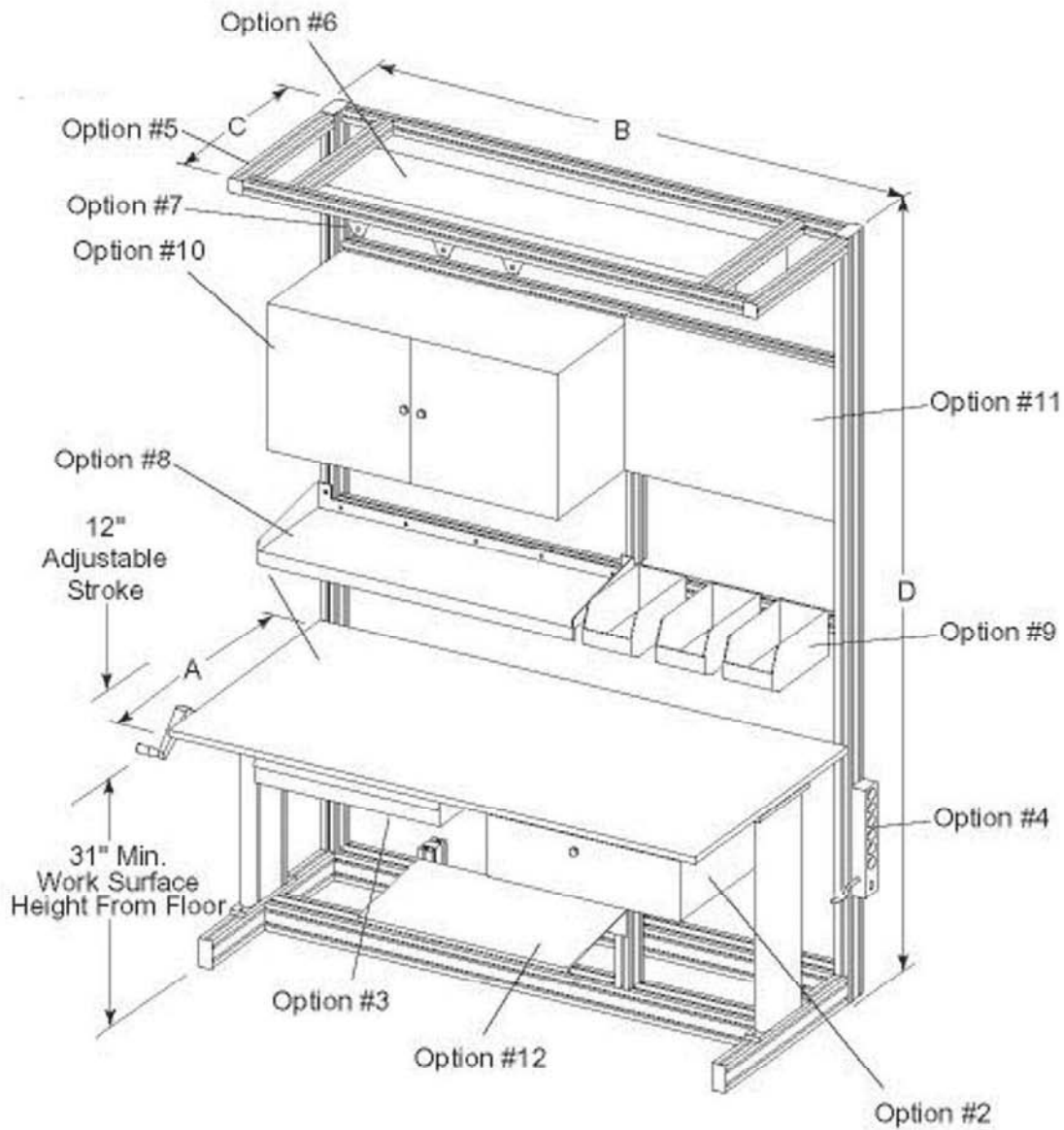

Example for Ordering:

WB3 - A - B - C - D - F1 - G1 - H - J - K - L1 - M - N - P1 - R1 - S - T - U
 (1-4) (1-2) (1-2) (1-4) (1-2)

A	_____ . _____ (Minimum with drawer is 24")
B	_____ . _____ (Minimum with both drawers is 40")
C	_____ . _____ (If Needed)
D	_____ . _____
F	Option #1 Table Top - Please specify material
F1	Stainless Steel
F2	Formica
F3	Hardwood Laminate
F4	Polypropelene
G	Option #2 Drawer w/ Sliding Tray & Keyed Lock
G1	13AC7462 - 16" w x 20"d x 6.75"h
G2	13AC7463 - 22" w x 20"d x 6.75"h
H	Option #3 Pencil Drawer
	13AC7460 - 21" w x 24"d x 3.00"h
J	Option #4 Electrical Access Strip
K	Option #5 Overhead Extension w/ Endcaps
L	Option #6 Light Fixture
L1	13AC7672 - 24" LG
L2	13AC7674 - 48" LG
M	Option #7 Tool Hanger
N	Option #8 Shelf - Specify Width
	Width _____ . _____
	Width _____ . _____
P	Option #9 Parts Container - Specify Color (Red, Blue, or Yellow)
P1	13AC7202 - 3"H x 4.13"D x 5.38"W
P2	13AC7203 - 3"H x 4.13"D x 5.38"W
P3	13AC7204 - 3"H x 4.13"D x 5.38"W
P4	13AC2105 - Parts Container Hanger
R	Option #10 Personal Effects Locker
R1	Keyed Lock
R2	Padlock Hasp
S	Option #11 Tack Board (Specify Size)
	Length _____ . _____ x Width _____ . _____
T	Option #12 Foot Rest
U	Option #13 Hydraulic Lift (Specify 500lb or 750lb Capacity)

Standard Base

There are four base styles available. Each of these styles will be constructed of 1.5" x 1.5", 1.5" x 3.0", or 3.0" x 3.0" aluminum extrusion specified. Top plates are available made from clear anodized aluminum, or blanchard ground steel that is not depicted in the images below.

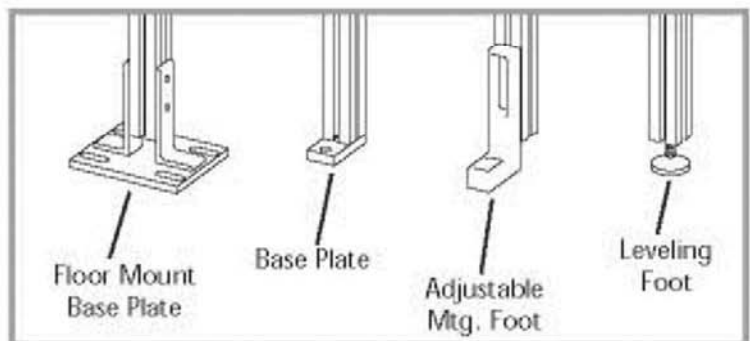
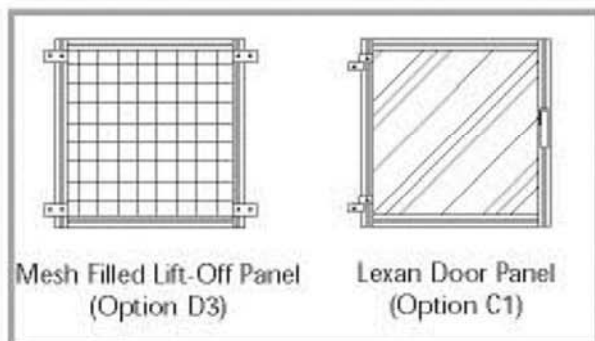
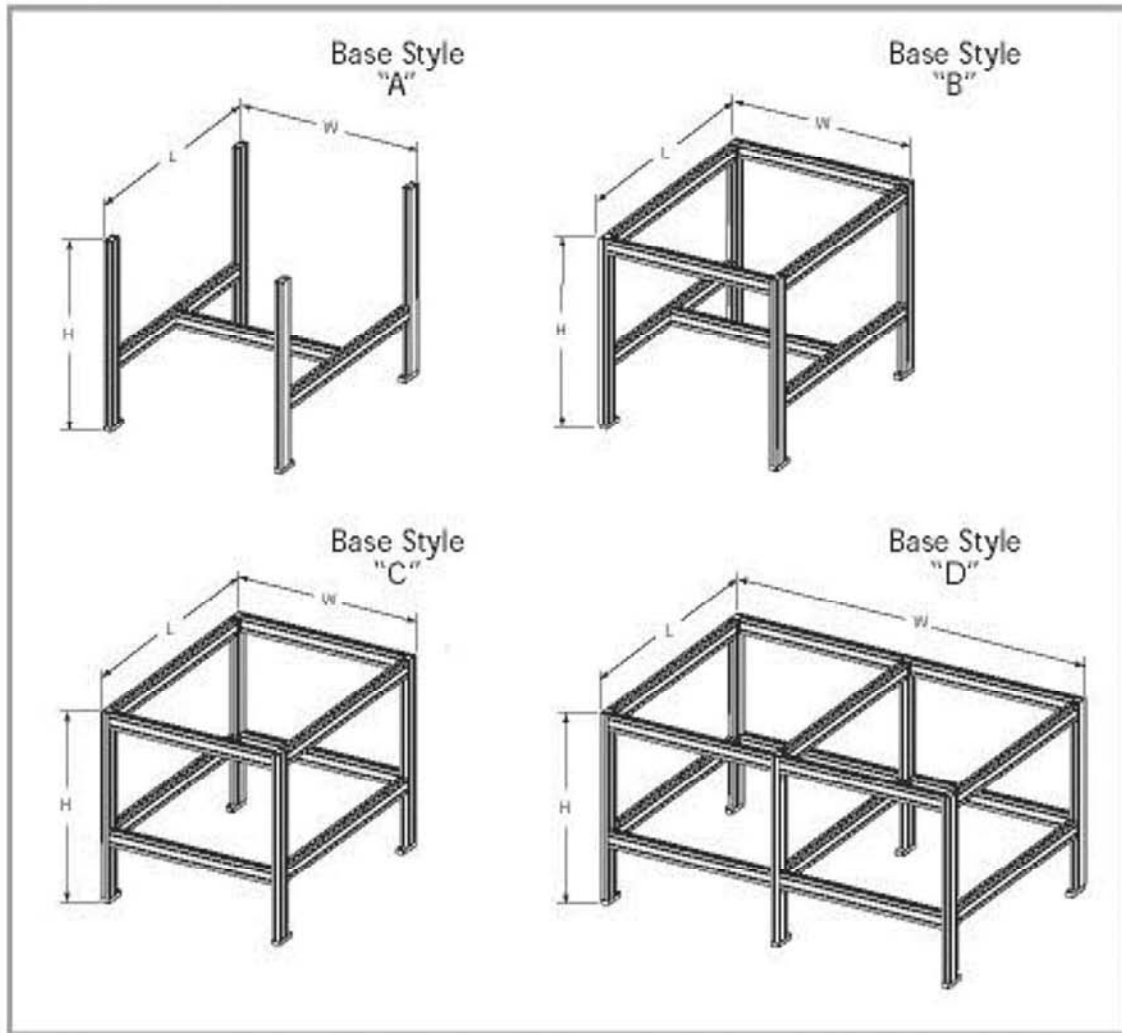

	Type A, B, C, or D
W	----- . -----
L	----- . -----
H	----- . -----
A	Option #1 Base Structure
A1	1.5" x 1.5" (Light)
A2	1.5" x 1.5" (Heavy)
A3	1.5" x 3.0" (Light)
A4	1.5" x 3.0" (Heavy)
A5	3.0" x 3.0" (Light)
A6	3.0" x 3.0" (Heavy)
B	Option #2 12 Gauge Steel Shelf (Styles C & D)
C	Option #3 Door Panels, Specify Side "L" and (or) "W"
C1	Polycarbonate
C2	Corrugate Aluminum
C3	PVC Coated 1" Wire Mesh
D	Option #3 Door Panels, Specify Side "L" and (or) "W"
D1	Polycarbonate
D2	Corrugate Aluminum
D3	PVC Coated 1" Wire Mesh
E	Option #5 Foot Type
E1	Floor Mount Base Plates
E2	Base Plate
E3	Adjustable Mounting Feet
E4	Leveling Feet
F	Option #6 Top Plate, Specify Thickness
F1	Aluminum Clear Anodized Finish _____ thk.
F2	Steel – Blanchard Ground _____ thk.
G	Option #7 Top Plate
G1	No Overhang – Flush With Sides
G2	Amount Overhang __ . _____ L" x __ . _____ W"

Example for Ordering:

SBA – W – L – H – A1 – B – C1L – D2L – E2 – F1 – G2 – (L – W)

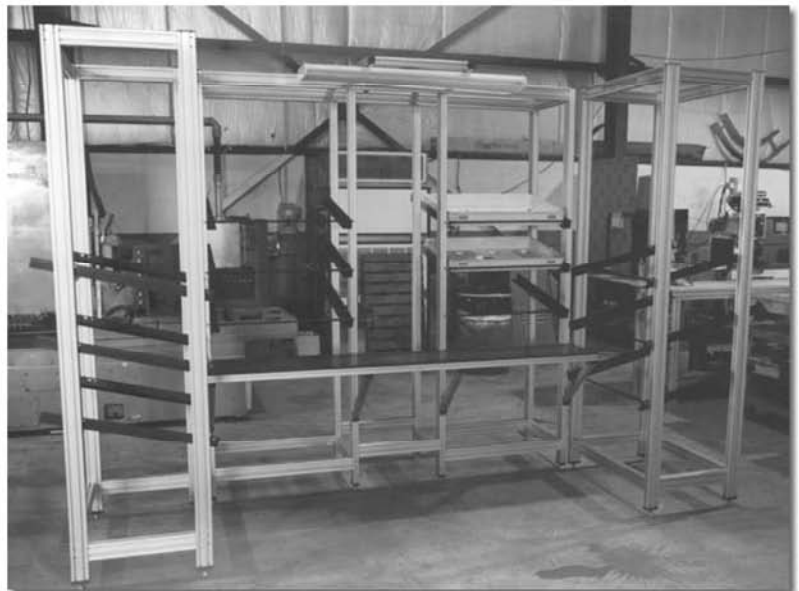
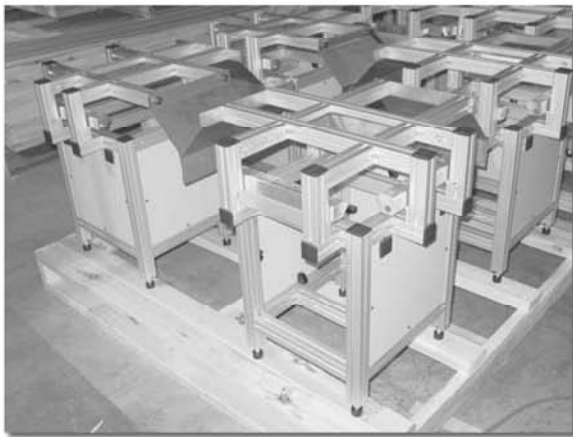

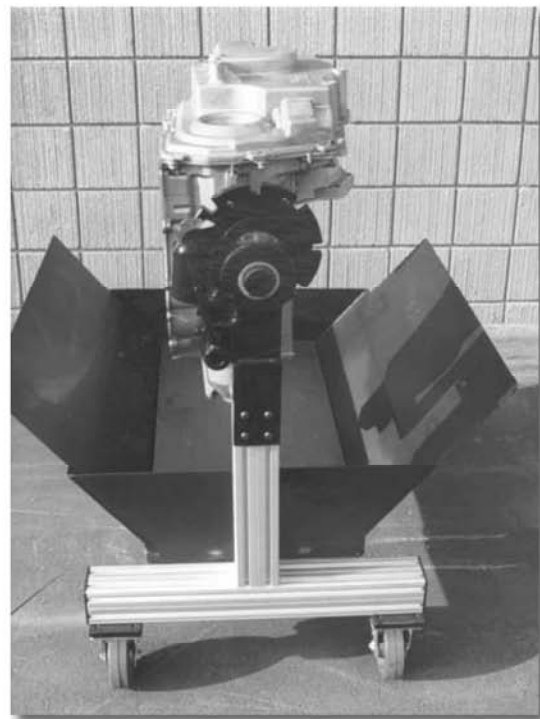

Prefab Prod.



PART NUMBER	PAGE #	PART NUMBER	PAGE #	PART NUMBER	PAGE #	PART NUMBER	PAGE #	PART NUMBER	PAGE #
10AC7400	327	10AC7902	258	10CB4105	274	10FA3121	300	10HI8215	322
10AC7401	237	10AC7950	339	10CB4106	270	10FA3122	300	10HI8216	322
10AC7402	237	10AC7953	339	10CB4107	275	10FA3123	300	10HI8225	322
10AC7630	237	10AC7955	339	10CB4108	275	10FA3124	300	10HI8227	322
10AC7632	237	10AC7957	339	10CB4110	270	10FA3125	300	10HI8260	320
10AC7634	237	10AC7976	333	10CB4111	271	10FA3128	300	10HI8262	320
10AC7730	237	10AC7978	333	10CB4112	271	10FA3200	327	10HI8300	310
10AC7732	237	10AC7980	334	10CB4113	271	10FA3700	305	10HI8302	310
10AC7734	237	10BP2560	290	10CB4114	272	10FA3705	306	10HI8304	311
10AC7736	237	10BP2564	290	10CB4115	272	10FAC3750	305	10HI8306	308
10AC7750	237	10BP2565	290	10CB4116	272	10FAC3755	306	10HI8308	308
10AC7751	237	10BP2566	290	10CB4117	273	10FAC3757	306	10HI8310	308
10AC7752	237	10BP2567	290	10CB4118	273	10FAC3758	305	10HI8312	308
10AC7753	237	10BP2568	290	10CB4119	273	10FF5611	292	10HI8313	310
10AC7760	237	10BP2569	290	10CB4120	275	10FF5612	292	10HI8315	308
10AC7762	334	10BP2570	291	10CB4121	274	10FF5613	293	10HI8317	308
10AC7763	331	10BP2571	291	10CB4221	267	10FF5614	293	10HI8320	311
10AC7768	334	10BP2572	291	10CB4222	267	10FF5820	294	10HI8321	313
10AC7800	333	10BP2573	291	10CB4223	267	10FF5821	294	10HI8322	313
10AC7801	333	10BP2574	291	10CB4224	268	10FF5823	294	10HI8323	313
10AC7803	335	10BP2575	289	10CB4225	268	10FF5824	294	10HI8324	313
10AC7805	337	10BP2576	289	10CB4226	268	10HI7810	319	10HI8325	313
10AC7806	335	10BP2577	289	10EX1010	260	10HI7813	318	10HI8326	313
10AC7809	335	10BP2578	289	10EX1020	261	10HI7814	317	10HI8327	313
10AC7810	337	10BP2579	290	10EX1030	262	10HI7815	317	10HI8328	313
10AC7814	337	10BP2588	287	10EX2020	263	10HI7816	319	10HI8329	314
10AC7815	336	10BP2589	288	10EX2040	264	10HI7818	319	10HI8330	314
10AC7816	336	10CB4100	269	10FA3100	300	10HI7820	319	10HI8331	314
10AC7817	336	10CB4101	274	10FA3101	300	10HI7821	319	10HI8332	314
10AC7850	332	10CB4102	269	10FA3102	300	10HI7822	319	10HI8333	314
10AC7855	332	10CB4103	269	10FA3103	300	10HI7823	318	10HI8334	314
10AC7901	258	10CB4104	270	10FA3104	300	10HI7824	317	10HI8335	314

PART NUMBER	PAGE #	PART NUMBER	PAGE #	PART NUMBER	PAGE #	PART NUMBER	PAGE #	PART NUMBER	PAGE #
10HI8336	314	10JP4204	277	10MA9003	324	10MFA3925	300	13AC7203	252
10HI8337	314	10JP4205	277	10MA9004	324	10SP1801	285	13AC7204	252
10HI8338	311	10JP4207	277	10MA9010	324	10SP1802	285	13AC7205	252
10HI8339	313	10JP4208	278	10MA9020	326	10SP1803	285	13AC7206	252
10HI8350	312	10JP4209	278	10MA9021	326	10SP1811	285	13AC7207	252
10HI8351	312	10JP4210	278	10MA9022	326	10SP1812	285	13AC7208	252
10HI8352	312	10JP4211	279	10MA9025	328	10SP1813	285	13AC7209	252
10HI8353	315	10JP4212	279	10MA9026	328	10SS7000	256	13AC7210	252
10H8354	315	10JP4213	280	10MA9027	328	10SS7001	256	13AC7230	236
10HI8355	315	10JP4214	280	10MA3030	328	10SS7002	256	13AC7232	236
10HI8356	315	10JP4215	280	10MA9031	328	10SS7003	256	13AC7268	249
10HI8357	315	10JP4216	281	10MA9032	328	10SS7004	257	13AC7270	236
10HI8358	315	10JP4217	281	10MA9033	328	10SS7005	300	13AC7272	236
10HI8359	315	10JP4218	281	10MA9034	328	10SS7006	300	13AC7274	236
10HI8360	315	10JP4220	282	10MA9035	325	10SS7007	256	13AC7276	236
10HI8361	315	10JP4225	282	10MA9051	324	10SS7008	256	13AC7278	236
10HI8362	315	10JP4226	282	10MA9052	324	10SS7009	256	13AC7280	236
10HI8363	315	10JP4227	283	10MA9053	324	10SS7011	256	13AC7282	236
10HI8364	315	10JPP4228	283	10MA9054	324	10SS7012	256	13AC7284	236
10HI8365	316	10JP4229	283	10MA9055	324	10SS7013	256	13AC7286	236
10HI8366	316	10JP4230	284	10MA9056	324	10SS7014	256	13AC7288	236
10HI8367	316	10JP4231	284	10MA9057	324	10SS7015	256	13AC7290	236
10HI8368	316	10LM8404	343	10MA9058	324	10SS7016	256	13AC7292	236
10HI8370	316	10LM8420	341	10MA9059	324	10SS7017	256	13AC7294	236
10HI8371	316	10LM8422	342	10MA9072	329	10SS7018	256	13AC7296	236
10HI8372	316	10LM8424	342	10MA9083	329	10SS7021	256	13AC7298	236
10HI8373	316	10LM8430	343	10MA9084	329	10SS7022	256	13AC7300	216
10HI8374	315	10LM8440	341	10MA9085	329	10SS7030	258	13AC7301	216
10HI8375	315	10LM8442	342	10MFA3125	300	13AC2101	252	13AC7302	216
10JP4201	276	10MA9000	324	10MFA3201	300	13AC2102	252	13AC7303	217
10JP4202	276	10MA9001	324	10MFA3202	300	13AC2105	253	13AC7305	221
10JP4203	276	10MA9002	324	10MFA3203	300	13AC7202	252	13AC7309	240

PART NUMBER	PAGE #	PART NUMBER	PAGE #	PART NUMBER	PAGE #	PART NUMBER	PAGE #	PART NUMBER	PAGE #
13AC7311	241	13AC7398	224	13AC7601	226	13CA8108	229	13FA3112	302
13AC7312	217	13AC7400	224	13AC7602	227	13CA8110	229	13FA3113	302
13AC7313	217	13AC7401	224	13AC7607	227	13CA8113	230	13FA3117	302
13AC7315	221	13AC7450	219	13AC7609	227	13CA8114	230	13FA3126	301
13AC7318	216	13AC7452	219	13AC7670	239	13CA8115	229	13FA3127	301
13AC7319	216	13AC7454	219	13AC7672	239	13CA8116	229	13FA3128	302
13AC7320	216	13AC7456	219	13AC7673	239	13CA8118	228	13FA3129	302
13AC7321	216	13AC7460	238	13AC7674	239	13CA8120	228	13FA3300	301
13AC7322	216	13AC7461	238	13AC7675	239	13CA8124	234	13FA3301	301
13AC7323	216	13AC7462	238	13AC7700	241	13CA8128	231	13FA3302	301
13AC7324	216	13AC7463	238	13AC7702	241	13CA8130	232	13FA3303	301
13AC7325	216	13AC7470	248	13AC7720	255	13CA8131	232	13FA3304	301
13AC7326	217	13AC7471	248	13AC7722	255	13CA8132	232	13FA3305	301
13AC7327	220	13AC7472	248	13AC7730	242	13CA8133	232	13FA3306	301
13AC7337	217	13AC7473	248	13AC7732	242	13CA8134	232	13FA3308	301
13AC7341	217	13AC7474	248	13AC7734	242	13CA8135	232	13FA3309	301
13AC7358	221	13AC7475	248	13AC7800	223	13CA8136	231	13FA3310	301
13AC7364	223	13AC7476	248	13AC7802	225	13CA8137	231	13FA3311	301
13AC7370	225	13AC7477	248	13AC7803	225	13CA8138	228	13FA3316	302
13AC7372	225	13AC7500	240	13AC7816	247	13CA8139	228	13FA3321	301
13AC7374	220	13AC7501	240	13AC7818	247	13CA8140	228	13FA3322	301
13AC7380	224	13AC7502	240	13AC7910	247	13CA8141	231	13FA3323	301
13AC7382	224	13AC7503	240	13AC7912	247	13CA8142	231	13FA3324	301
13AC7384	224	13AC7504	240	13AC8700	244	13CA8143	231	13FA3325	301
13AC7390	224	13AC7505	240	13CA8100	228	13CA8144	231	13FA3326	301
13AC7391	224	13AC7506	240	13CA8101	228	13CA8145	231	13FA3327	301
13AC7392	223	13AC7507	240	13CA8102	229	13CA8154	228	13FA3328	301
13AC7393	224	13AC7508	240	13CA8103	229	13CB5000	250	13FA3329	301
13AC7394	224	13AC7509	240	13CA8104	230	13CB5001	250	13FA3330	301
13AC7395	224	13AC7510	240	13CA8105	231	13CB5002	250	13FA3331	301
13AC7396	224	13AC7511	240	13CA8106	230	13FA3110	301	13FA3335	301
13AC7397	224	13AC7600	226	13CA8107	231	13FA3111	301	13FA3336	301

PART NUMBER	PAGE #	PART NUMBER	PAGE #	PART NUMBER	PAGE #	PART NUMBER	PAGE #	PART NUMBER	PAGE #
13FA3337	301	13FA3710	301	13HI8106	155	13MFA3613	303	13PA8308	243
13FA3338	302	13FA3712	301	13HI8107	155	13MFA3614	303	13PA8309	243
13FA3340	302	13FA7320	301	13HI8108	155	13MFA3615	303	13PA8310	243
13FA3342	301	13FA3721	301	13HI8109	155	13MFA3616	303	13PA8311	243
13FA3345	302	13FA3722	301	13HI8110	155	13MFA3617	303	13PA8312	243
13FA3346	302	13FA3723	301	13HI8111	155	13MFA3618	303	13PA8313	243
13FA3347	302	13FF8113	234	13JP6000	251	13MFA3619	303	13PA8314	243
13FA3348	302	13FF8114	234	13JP6001	251	13MFA3620	303	13PA8320	243
13FA3350	302	13FF8115	235	13JP6002	251	13MFA3621	303	13PA8321	243
13FA3351	302	13FF8116	235	13MA9070	255	13MFA3622	303	13PA8322	243
13FA3352	302	13FF8117	235	13MA9071	256	13MFA3624	303	13PA8324	243
13FA3353	301	13FF8118	235	13MA9080	329	13MFA3640	303	13PA8325	243
13FA3354	301	13FF8119	235	13MA9081	329	13MFA3641	303	13PA8326	243
13FA3360	301	13FF8120	235	13MA9086	329	13MFA3642	303	13PA8327	243
13FA3362	301	13FF8121	235	13MA9088	329	13MFA3643	303	13PA8328	243
13FA3602	301	13FF8122	235	13MA9089	329	13MFA3644	303	13PA8329	243
13FA3603	301	13FF8123	235	13MA9090	329	13MFA3645	303	13PA8340	243
13FA3604	301	13FF8124	235	13MA9091	329	13MFA3646	436	13PA8341	243
13FA3605	301	13FF8125	235	13MA9092	329	13MFA3647	303	13PA8342	243
13FA3606	301	13FF8126	235	13MA9094	329	13MFA3648	303	13PA8343	243
13FA3607	302	13FF8127	235	13MA9096	329	13MFA3649	303	13PA8344	243
13FA3608	302	13FF8128	235	13MA9100	329	13MFA3650	303	13PA8345	243
13FA3609	302	13FF8129	235	13MFA3600	303	13MFA3651	303	13PA8346	243
13FA3610	302	13FF8131	235	13MFA3602	303	13MFA3652	303	13PA8347	243
13FA3611	302	13FF8132	235	13MFA3605	303	13MFA3653	303	13PA8350	243
13FA3612	301	13FF8133	235	13MFA3606	303	13MFA3654	303	13PA8351	243
13FA3613	301	13HI8100	319	13MFA3607	303	13MFA3655	303	13PA8352	243
13FA3700	302	13HI8101	319	13MFA3608	303	13PA8301	243	13PA8360	243
13FA3701	302	13HI8102	319	13MFA3609	303	13PA8304	243	13PA8361	243
13FA3704	302	13HI8103	319	13MFA3610	303	13PA8305	243	13PA8365	243
13FA3708	301	13HI8104	319	13MFA3611	303	13PA8306	243	13PA8366	243
13FA3709	301	13HI8105	319	13MFA3612	303	13PA8307	243	13PA8367	243

PART NUMBER	PAGE #	PART NUMBER	PAGE #	PART NUMBER	PAGE #	PART NUMBER	PAGE #	PART NUMBER	PAGE #
13PA8370	243	15AC7113	188	15AC7942	173	15AC8715	195	15AC8804	197
13PA8371	243	15AC7114	185	15AC7944	173	15AC8716	195	15AC8850	183
13SS8001	258	15AC7115	187	15AC7946	173	15AC8717	195	15AC8852	183
13TL1201	254	15AC7116	188	15AC7950	179	15AC8725	193	15BP2500	106
13TL1202	254	15AC7117	185	15AC7951	179	15AC8726	193	15BP2501	107
13TL1203	254	15AC7118	187	15AC7953	179	15AC8727	193	15BP2502	111
13TL1206	254	15AC7119	187	15AC7955	179	15AC8748	191	15BP2503	110
13TL1207	254	15AC7305	192	15AC7956	179	15AC8749	192	15BP2508	115
13TL1208	254	15AC7310	176	15AC7957	179	15AC8750	175	15BP2511	117
13TL1210	254	15AC7500	166	15AC7958	180	15AC8751	175	15BP2512	113
13TL1301	254	15AC7501	166	15AC7962	180	15AC8752	175	15BP2513	115
13TL1302	254	15AC7502	166	15AC7972	180	15AC8753	175	15BP2514	115
13TL1303	254	15AC7505	167	15AC7974	182	15AC8758	175	15BP2515	117
13TL1306	254	15AC7825	172	15AC7976	182	15AC8760	175	15BP2516	113
13TL1307	254	15AC7830	172	15AC7978	181	15AC8762	181	15BP2517	114
13TL1308	254	15AC7832	172	15AC7980	182	15AC8768	181	15BP2518	114
13TL1312	254	15AC7840	173	15AC7984	180	15AC8770	176	15BP2519	116
13TL1313	254	15AC7842	173	15AC8502	193	15AC8771	176	15BP2520	118
13TL1401	254	15AC7844	173	15AC8503	193	15AC8772	176	15BP2521	108
13TL1402	254	15AC7909	174	15AC8505	193	15AC8774	177	15BP2522	112
13TL1450	254	15AC7911	174	15AC8700	191	15AC8780	258	15BP2523	109
13TL1501	254	15AC7913	174	15AC8702	191	15AC8781	258	15BP2524	119
13TL1502	254	15AC7915	174	15AC8703	191	15AC8782	177	15BP2550	114
13TL1600	255	15AC7917	174	15AC8706	194	15AC8784	177	15BP2551	114
13TL1700	255	15AC7919	174	15AC8707	194	15AC8786	192	15BP2552	116
13TL1801	254	15AC7921	174	15AC8708	195	15AC8788	167	15BP2553	118
13TL1802	254	15AC7923	174	15AC8709	194	15AC8790	175	15BP2561	115
15AC7105	184	15AC7925	172	15AC8710	195	15AC8791	175	15BP2562	115
15AC7107	184	15AC7930	172	15AC8711	195	15AC8800	197	15BP2563	117
15AC7109	184	15AC7932	172	15AC8712	194	15AC8801	197	15BP2564	115
15AC7110	188	15AC7934	172	15AC8713	194	15AC8802	197	15BP2580	115
15AC7112	185	15AC7940	173	15AC8714	194	15AC8803	197	15BP2583	117

PART NUMBER	PAGE #	PART NUMBER	PAGE #	PART NUMBER	PAGE #	PART NUMBER	PAGE #	PART NUMBER	PAGE #
15BP2585	117	15CB4849	81	15FA3509	130	15FF5814	120	15H8725	154
15BP2587	117	15CB4850	86	15FA3511	130	15FF5815	122	15H8726	154
15BP2588	119	15CB4851	81	15FA3513	130	15FF5816	121	15H8727	154
15BP2589	119	15CB4852	81	15FA3515	130	15FF5818	122	15H8728	153
15BP2590	119	15CB4856	84	15FA3516	130	15FF5820	126	15H8729	152
15CB4000	73	15CB4857	82	15FA3520	130	15FF5822	120	15H8732	155
15CB4001	73	15CB4860	82	15FA3522	130	15FF5824	121	15H8738	155
15CB4002	73	15CB4861	83	15FA3524	130	15FF5830	123	15H8749	155
15CB4003	74	15CB4862	84	15FA3526	130	15FF5833	123	15H8750	152
15CB4004	74	15CB4863	85	15FA3530	130	15FF5835	124	15H8800	143
15CB4005	74	15CB4865	86	15FA3532	130	15FF5838	124	15H8802	144
15CB4801	76	15CB4866	87	15FA3534	130	15FF5850	125	15H8803	143
15CB4802	76	15EX1515	53	15FA3536	130	15FF5852	125	15H8805	144
15CB4803	76	15EX1515L	44	15FA3538	130	15H8514	158	15H8806	144
15CB4804	77	15EX1515UL	43	15FA3540	130	15H8515	156	15H8808	146
15CB4805	77	15EX1517L	51	15FA3542	130	15H8518	157	15H8810	145
15CB4806	77	15EX1530	59	15FA3544	130	15H8522	158	15H8812	145
15CB4808	78	15EX1530L	56	15FA3556	130	15H8526	158	15H8814	145
15CB4811	78	15EX1545L	62	15FA3558	130	15H8527	158	15H8816	143
15CB4812	78	15EX3030	64	15FA3600	130	15H8530	157	15H8820	149
15CB4813	79	15EX3060	67	15FA3610	137	15H8536	157	15H8821	149
15CB4815	79	15FA3300	166	15FA3615	141	15H8550	156	15H8822	149
15CB4816	79	15FA3403	130	15FAC3865	141	15H8560	159	15H8823	149
15CB4817	80	15FA3405	130	15FAC3880	137	15H8562	159	15H8824	149
15CB4818	80	15FA3407	130	15FAC3882	138	15H8704	154	15H8825	149
15CB4840	82	15FA3501	130	15FAC3884	138	15H8712	146	15H8826	149
15CB4841	83	15FA3502	130	15FAC3886	138	15H8715	146	15H8827	149
15CB4842	84	15FA3503	130	15FAC3888	137	15H8720	153	15H8828	149
15CB4843	85	15FA3504	130	15FAC3890	136	15H8721	152	15H8829	148
15CB4844	85	15FA3505	130	15FAC3892	139	15H8722	153	15H8830	148
15CB4845	80	15FA3506	130	15FAC3894	140	15H8723	154	15H8831	148
15CB4846	86	15FA3507	130	15FAC3896	139	15H8724	154	15H8832	148

PART NUMBER	PAGE #	PART NUMBER	PAGE #	PART NUMBER	PAGE #	PART NUMBER	PAGE #	PART NUMBER	PAGE #
15HI8833	148	15JP4500	88	15JP4532	98	15LM8570	203	15MA9055	161
15HI8834	148	15JP4501	88	15JP4533	99	15LM8572	203	15MA9056	161
15HI8835	148	15JP4502	88	15JP4534	99	15LM8574	203	15MA9057	161
15HI8836	148	15JP4503	88	15JP4535	99	15LM8590	212	15MA9058	161
15HI8837	148	15JP4504	89	15JP4536	100	15LM8702	206	15MA9059	161
15HI8850	146	15JP4505	89	15JP4537	100	15LM8704	208	15MA9060	165
15HI8852	146	15JP4506	90	15JP4538	100	15LM8706	208	15MA9061	165
15HI8860	147	15JP4507	90	15JP4539	101	15LM8708	206	15MA9062	169
15HI8861	147	15JP4508	90	15JP4540	101	15LM8710	208	15MA9063	169
15HI8862	147	15JP4509	91	15JP4545	101	15LM8712	208	15MA9064	169
15HI8863	150	15JP4510	91	15JP4546	102	15LM8714	206	15MA9065	169
15HI8864	150	15JP4511	91	15JP4547	102	15LM8716	209	15MA9066	169
15HI8865	150	15JP4512	92	15JP4548	102	15LM8718	209	15MA9067	169
15HI8866	150	15JP4513	92	15LG1515L	207	15LM8720	206	15MA9068	169
15HI8867	150	15JP4514	92	15LM8504	213	15LM8722	209	15MA9069	169
15HI8868	150	15JP4515	93	15LM8506	211	15LM8724	209	15MA9070	164
15HI8869	150	15JP4516	93	15LM8516	210	15LM8725	208	15MA9071	163
15HI8870	150	15JP4517	93	15LM8518	210	15LM8726	208	15MA9072	168
15HI8871	150	15JP4518	94	15LM8520	210	15LM8730	206	15MA9073	165
15HI8872	150	15JP4519	94	15LM8530	213	15LM8732	206	15MA9074	162
15HI8873	150	15JP4520	94	15LM8532	212	15MA9006	161	15MA9077	161
15HI8874	150	15JP4521	95	15LM8536	213	15MA9007	161	15MA9078	161
15HI8879	151	15JP4522	95	15LM8540	210	15MA9008	161	15MA9079	161
15HI8880	151	15JP4523	95	15LM8542	214	15MA9009	161	15MA9083	169
15HI8881	151	15JP4524	96	15LM8543	214	15MA9011	161	15MA9084	169
15HI8882	151	15JP4525	96	15LM8544	214	15MA9046	161	15MA9085	169
15HI8883	151	15JP4526	96	15LM8545	214	15MA9047	161	15MFA3900	131
15HI8884	151	15JP4527	97	15LM8546	214	15MA9050	161	15MFA3902	131
15HI8885	151	15JP4528	97	15LM8560	204	15MA9051	161	15MFA3920	131
15HI8886	151	15JP4529	97	15LM8561	204	15MA9052	161	15MFA3920	131
15HI8887	151	15JP4530	98	15LM8562	205	15MA9053	161	15MFA3921	131
15HI8888	151	15JP4531	98	15LM8563	205	15MA9054	161	15MFA3922	131

PART NUMBER	PAGE #	PART NUMBER	PAGE #	PART NUMBER	PAGE #	PART NUMBER	PAGE #	PART NUMBER	PAGE #
15MFA3923	131	15QE3030L-4	63	15SP1873	104	15SS8045	257	25CB4353	357
15MFA3925	131	15QE3060	68	15SP1874	104	15SS8046	257	25CB4355	355
15MFA3926	131	15QE3060-2	68	15SP1875	104	15SS8047	256	25CB4356	357
15MFA3928	131	15QEA1515L	48	15SP1876	104	15SS8049	255	25MFA3244	365
15MFA3932	131	15QEA1515L-16	48	15SP1877	104	15SS8075	404	25MFA3246	365
15MFA3934	131	15QEB1515L	49	15SP1878	104	15SS8076	404	25QE2525	345
15MFA3936	131	15QEB1515L-16	49	15SP1879	104	25AC7309	383	25QE2525-9	345
15MFA3938	131	15QEM1515L	47	15SP1880	104	25AC7726	381	25QE2530	349
15MFA3940	131	15SM1515	55	15SP1881	104	25AC7728	381	25QE2530-9	349
15MFA3942	131	15SM1515L	46	15SP1882	104	25AC7730	381	25QE2550	350
15MFA3710	131	15SM1530	61	15SP1883	104	25AC7732	381	25QE2550-18	350
15MFA3720	131	15SM1530L	58	15SP1884	104	25AC7734	381	25QE2575	351
15MFA3722	131	15SM3030	66	15SS8000	256	25AC7740	382	25QE2575-12	351
15MFA3724	131	15SP1850	103	15SS8001	256	25AC7820	383	25QE5050	352
15MFA3728	131	15SP1851	103	15SS8002	256	25AC7828	383	25QE5050-9	352
15QE1515	54	15SP1852	103	15SS8003	256	25AC7830	384	25QEA2525	346
15QE1515-16	54	15SP1853	103	15SS8004	257	25AC7832	382	25QEA2525-9	346
15QE1515L	45	15SP1854	103	15SS8005	257	25AC7834	383	25QEB2525	347
15QE1515L-16	45	15SP1855	103	15SS8006	258	25AC7836	382	25QEB2525-9	347
15QE1517L	52	15SP1856	103	15SS8007	129	25AC7972	384	25QEM2525	348
15QE1517L-16	52	15SP1857	103	15SS8008	256	25AC7974	384	25QEM2525-9	348
15QE1530	60	15SP1860	103	15SS8009	256	25BP2520	360	25SP1801	358
15QE1530-8	60	15SP1861	103	15SS8010	256	25BP2521	360	25SP1802	358
15QE1530L	57	15SP1862	103	15SS8011	256	25BP2522	360	25SP1803	358
15QE1530L-8	57	15SP1863	103	15SS8012	256	25BP2527	361	40AC7925	419
15QE1717L	69	15SP1865	103	15SS8015	256	25BP2528	361	40AC7930	419
15QE1717L-9	69	15SP1866	103	15SS8016	256	25CB4347	355	40BP2520	398
15QE2323L	70	15SP1867	103	15SS8017	129	25CB4348	355	40BP2521	398
15QE2323L-9	70	15SP1868	103	15SS8018	256	25CB4349	356	40BP2522	398
15QE3030	65	15SP1870	104	15SS8019	258	25CB4350	356	40CB4801	392
15QE3030-4	65	15SP1871	104	15SS8020	256	25CB4351	356	40CB4802	392
15QE3030L	63	15SP1872	104	15SS8035	256	25CB4352	357	40CB4803	392

PART NUMBER	PAGE #	PART NUMBER	PAGE #	PART NUMBER	PAGE #	PART NUMBER	PAGE #	PART NUMBER	PAGE #
40CB4804	393								
40CB4805	393								
40CB4806	393								
40EX4040UL	388								
40EX4080UL	389								
40FF5822	399								
40FF5824	399								
40HI8530	410								
40HI8540	410								
40HI8712	410								
40JP4501	394								
40JP4502	394								
40JP4504	394								
40JP4506	394								
40JP4507	394								
40JP4509	394								
40MFAC3720	407								
40MFAC3730	408								