

# SECTION 15

## 10 SERIES

### MACHINING SERVICES

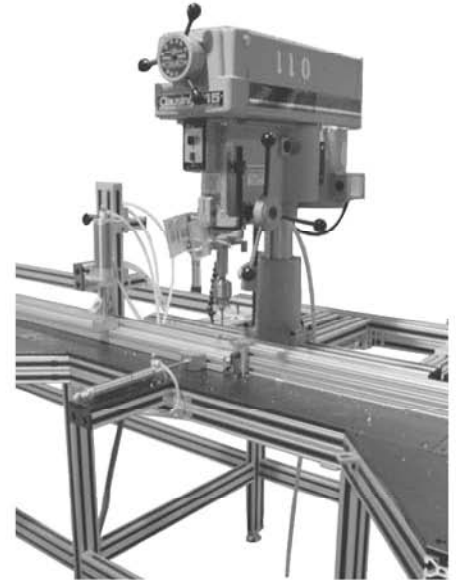
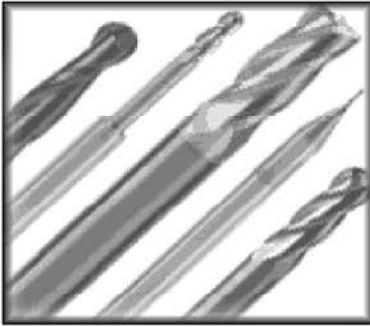

Machining

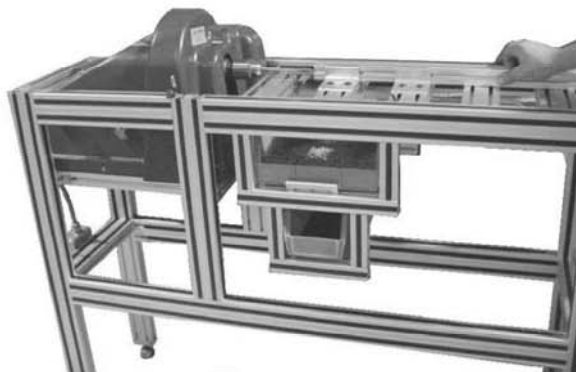
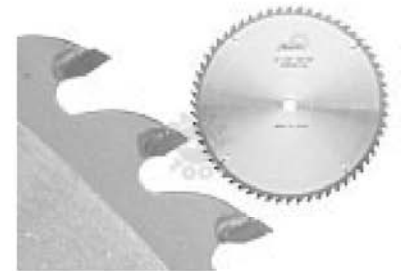
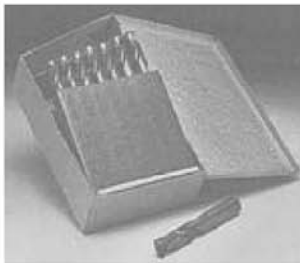

#### **ADVANTAGES**

- FAST
- CLEAN
- ACCURATE
- CONVENIENT
- COST EFFECTIVE

## 10 SERIES CUT TO LENGTH SERVICES (T-Slotted Extrusions)

SERVICE NUMBER	DESCRIPTION
10MA9000	CUT TO LENGTH 10EX1010
10MA9001	CUT TO LENGTH 10EX1020
10MA9003	CUT TO LENGTH 10EX1030
10MA9002	CUT TO LENGTH 10EX2020
10MA9004	CUT TO LENGTH 10EX2040

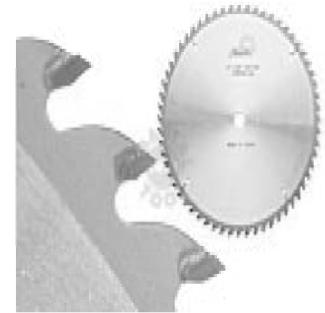

Faztek will cut your order for you on our state of the art saw equipment!

**BENEFITS:**

- *State of the art saws*
- *Tolerance on cuts are +/- .015"*
- *Squareness of cuts are .002" per inch*
- *Extrusions up to 100" can be shipped via*



UPS and the UPS brandmark are registered trademarks that are used with permission by its owner, United Parcel Service of America, Inc. All rights reserved.

## 10 SERIES EXTRUSION END TAPS

SERVICE NUMBER	DESCRIPTION
10MA9010	1/4-20 TAP FOR 10EX1010
10MA9051	1/4-20 TAP FOR 10EX1020
10MA9056	1/4-20 TAP FOR 10EX1030
10MA9052	1/4-20 TAP FOR 10EX2020
10MA9057	1/4-20 TAP FOR 10EX2040
10MA9053	M6 x 1.00 TAP FOR 10EX1010
10MA9054	M6 x 1.00 TAP FOR 10EX1020
10MA9058	M6 x 1.00 TAP FOR 10EX1030
10MA9055	M6 x 1.00 TAP FOR 10EX2020
10MA9059	M6 x 1.00 TAP FOR 10EX2040

**WHY TAP YOUR EXTRUSIONS?**

- *End fasteners - page 306*
- *Casters - page 228-234*
- *Base plates - pages 287-291*
- *Leveling feet - page 234-235*
- *Endcaps - page 331*
- *Joining Plates - pages 276-284*

**NOTE:**

- **Service is per end**

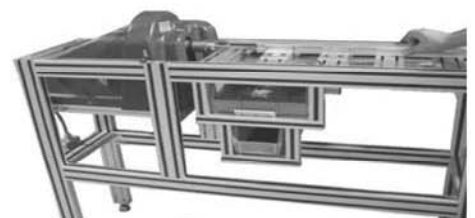

# 10 SERIES ANCHOR / BUTT FASTENER COUNTERBORES

SERVICE NUMBER	DESCRIPTION
10MA9035	10 SERIES COUNTERBORE DRILLING SERVICE
	ANCHOR / BUTT FASTENERS - USE SAME SERVICE

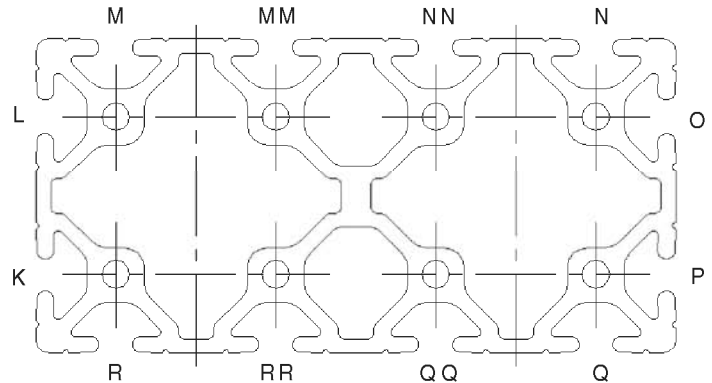
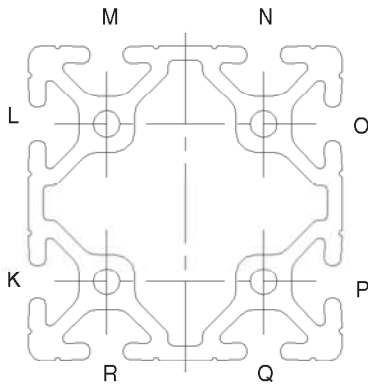
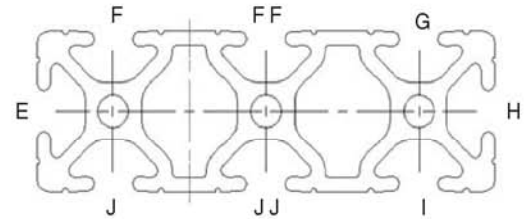
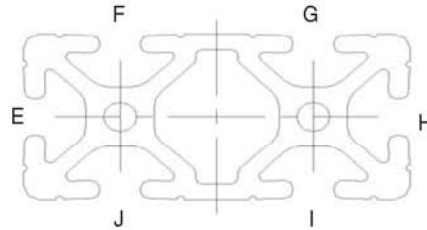
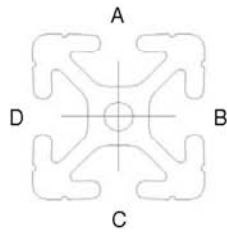

Machining

**BENEFITS:**

- **STRONGEST** of all connections
- Tolerance on counterbores are +/- .015"
- Infinite positioning when using anchors
- Clean, flush look!

**Assembly Tip**

Extrusions shorter than 4.00" Long cannot be assembled if counterbored "A" both ends. The part does not provide enough clearance for a wrench to access the fastener and properly tighten it down.

**EXTRUSION DETAIL**

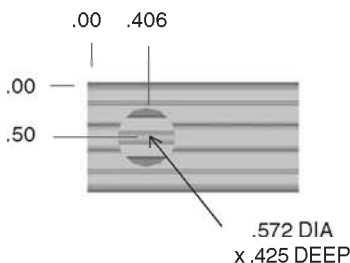

**STYLE EXAMPLE**

10EX1010 x 35.00" W/10MA9035 IN A BOTH ENDS

(this service will include 2 counterbores)

10EX2020 x 62.00" W/ 10MA9035 IN KLOP BOTH ENDS

(this service will include 8 counterbores)

# 10 SERIES ACCESS HOLE DRILLING SERVICE



SERVICE #	DESCRIPTION
10MA9020	ACCESS HOLE DRILLING SERVICE (.218 DIA) - STANDARD
10MA9021	ACCESS HOLE DRILLING SERVICE (.06 TO .217 DIA)
10MA9022	ACCESS HOLE DRILLING SERVICE (.219 TO .375 DIA)

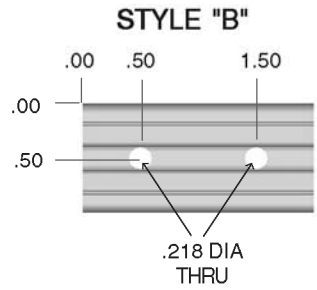
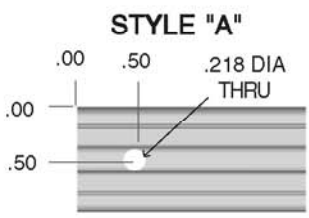
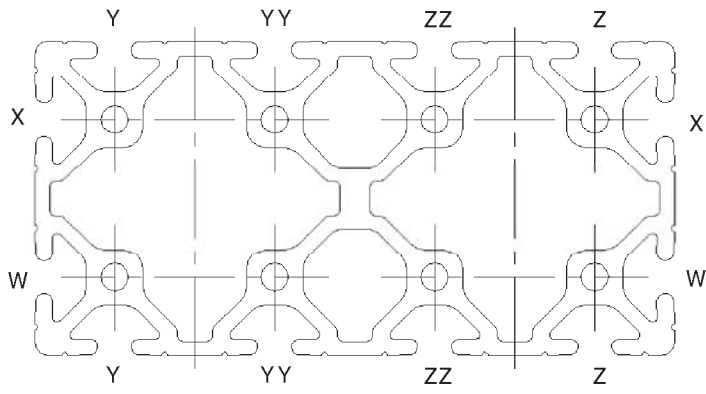
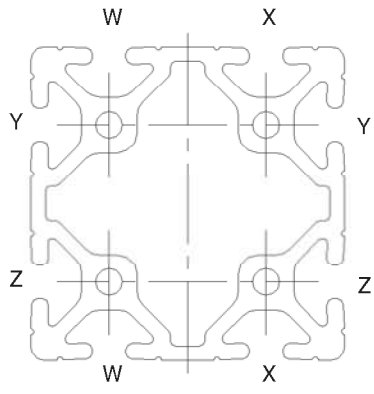
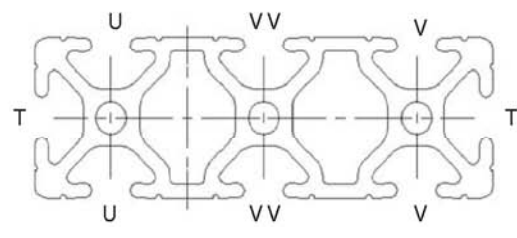
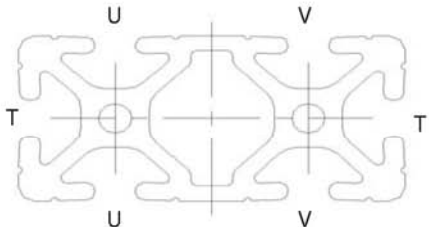
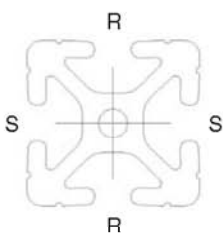

**BENEFITS:**

- Quick, accurate alignment
- Tolerance on access holes are +/- .030"
- Allows for smaller panel notches
- Clean, hidden look!



**OPEN STYLE EXAMPLE**

10EX1020 x 15" W/10MA9020 IN U @ .75, 5.00 AND IN V @ .75, 10.50  
(this service will include 4 access holes)

**STYLE A EXAMPLE**

10EX1010 x 45" W/10MA9020 IN R @ STYLE A BOTH ENDS  
(this service will include 2 access holes)

TO DRILL YOUR OWN ACCESS HOLES, SEE PAGE 327

### 10AC7400

10 SERIES  
10EX1010 ACCESS HOLE DRILL JIG

**Hardware Included!**

- Drill access holes on site
- Dowel pins used to eliminate pivot point
- Fast
- Hardened drill bushings for long life

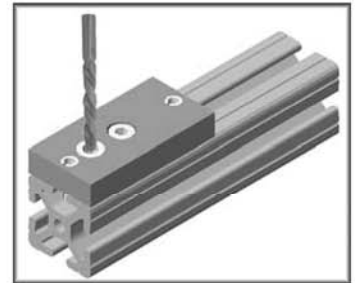
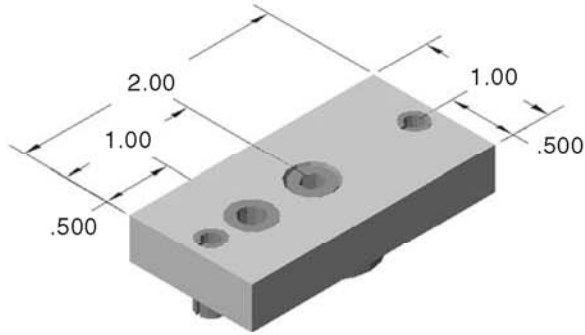

### 10AC7401

10 SERIES  
10EX1020 ACCESS HOLE DRILL JIG

**Hardware Included!**

- Drill access holes on site
- Dowel pins used to eliminate pivot point
- Fast
- Hardened drill bushings for long life

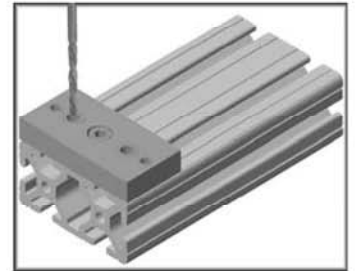
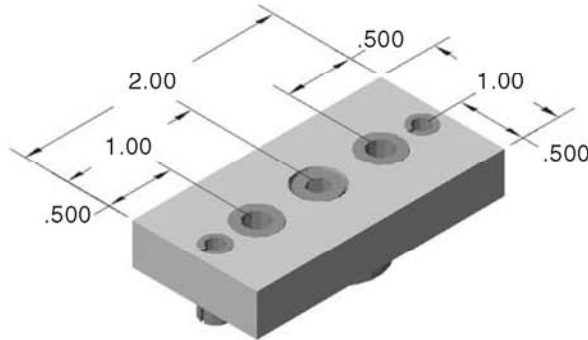

Machining

### 10AC7402

10 SERIES  
10EX2020 ACCESS HOLE DRILL JIG

**Hardware Included!**

- Drill access holes on site
- Dowel pins used to eliminate pivot point
- Fast
- Hardened drill bushings for long life

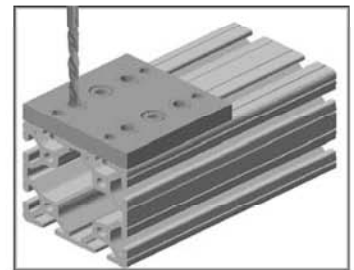
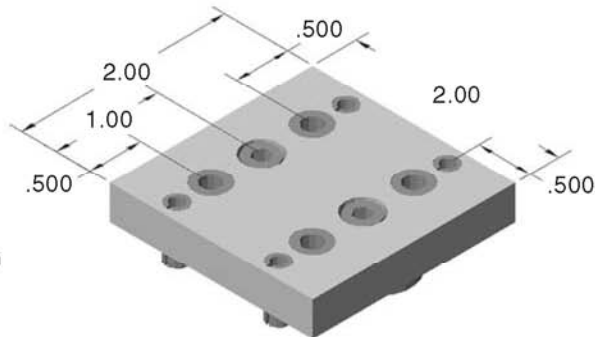

### 10FA3200

REPLACEMENT DRILL BUSHING

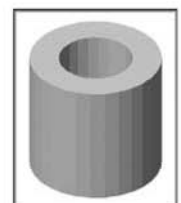
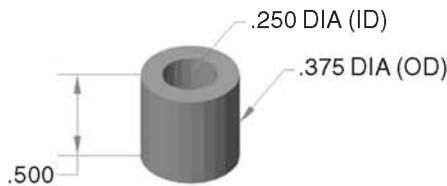

## 10 SERIES CUSTOM MITER CUTS

SERVICE NO.	DESCRIPTION
10MA9025	MITER CUT SERVICE FOR 10EX1010
10MA9026	MITER CUT SERVICE FOR 10EX1020
10MA9032	MITER CUT SERVICE FOR 10EX1030
10MA9027	MITER CUT SERVICE FOR 10EX2020
10MA9034	MITER CUT SERVICE FOR 10EX2040

- All 10 series extrusions can be miter cut from 30° to 90° except 10EX2040
- Maximum miter cut for 10EX2040 is 45° across the 4" face

Contact Faztek to request a standard miter cut template!

- Please submit a drawing with all miter cuts
- Service is per end
- Great support for heavy duty applications
- For standard 45° supports, see page 285

## 10 SERIES MITER CUTS AND COUNTERBORES

SERVICE NO.	DESCRIPTION
10MA9030	MITER CUT & C-BORE FOR 10EX1010
10MA9031	MITER CUT & C-BORE FOR 10EX1020
10MA9033	MITER CUT & C-BORE FOR 10EX1030

- 10 series extrusions can be miter cut and counterbored from 45° to 90°
- Please submit a drawing with any mitercut and c-bore
- Maximum length of 72" - DUE TO SAFETY ISSUES!!
- Service is per end

Hardware Included!

Contact Faztek to request a standard miter cut template!



## DOOR LATCH MACHINING SERVICES

**13MA9100**

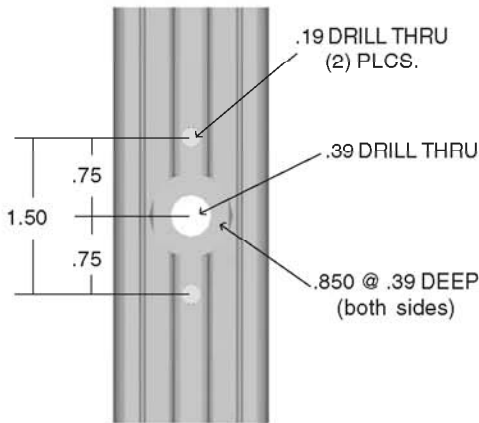

**10MA9072**

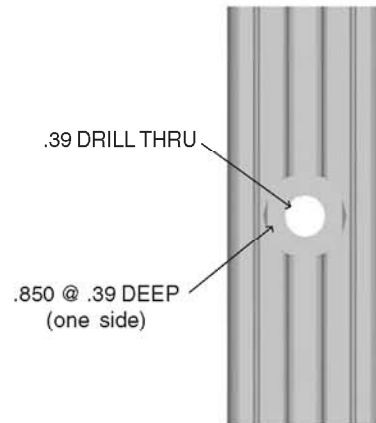

SERVICE NUMBER	DESCRIPTION
13MA9100	DELUXE DOOR HANDLE MACHINING SERVICE
10MA9072	STANDARD DOOR HANDLE MACHINING SERVICE

Machining



Use the following T-Slot designations when ordering an extrusion with a door latch service.

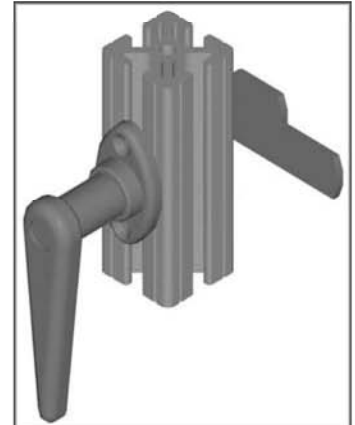
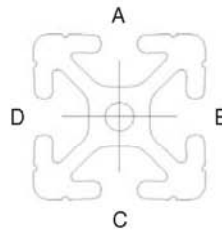

## UNIVERSAL PANEL & WIRE MACHINING SERVICES

SERVICE NO.	DESCRIPTION
13MA9080	CUTTING PLASTIC / WIRE ALL SIDES LESS THAN 48"
13MA9081	CUTTING PLASTIC / WIRE ANY SIDE GREATER THAN 48"
10MA9083	ANCHOR FASTENER NOTCH FOR PANEL / WIRE <b>FOR 10 SERIES</b>
10MA9084	END FASTENER NOTCH FOR PANEL / WIRE <b>FOR 10 SERIES</b>
10MA9085	EXTRUSION CLEARANCE NOTCH FOR PANEL / WIRE <b>FOR 10 SERIES</b>
13MA9086	EDGE RADIUS FOR PLASTIC PANELS - PER SIDE
13MA9088	DRILL THRU ON PLASTIC PANEL (UP TO .50 DIA HOLES)
13MA9089	90° CUTOUTS FOR PANEL / WIRE
13MA9090	DRILL / TAP THRU PLASTIC PANEL (UP TO 7/16-14 TAP THRU)
13MA9091	DRILL / C-SINK FOR PLASTIC PANEL (UP TO 5/16 C'SINK)
13MA9092	DRILL THRU ON PLASTIC PANEL (.501 DIA TO 5.00 DIA HOLES)
13MA9094	EXTRUSION PROFILE NOTCH FOR PANEL / WIRE
13MA9096	GRABBER DOOR CATCH MACHINING FOR PLASTIC PANEL

Contact Faztek to request a standard panel template!

- *Please submit a drawing with any panel machining*
- *A great compliment to our product offering*
- *Contact Faztek for custom machined panels*